

# PRODUCT SPEC SHEET

**BOBO**  
/SOFAS

PROCESS	All the fabric wooden and foam material cuts of Font Sofa are made in CNC machines according to technical drawings. Also all of our upholstering processes are handcrafted by our expert craftsmen.
DESIGNED BY	ADAM D LAB
TYPE	INDOOR SOFA
DIMENSIONS	Sectional Sofa: L 260 D 90/165 H 65
DESCRIPTION	Removable metal legs via screwer Soft plastic glides avoiding the floor damage attached under the legs of all kind Moveable seat back cushions Removable back cushion covers Additional two small cushions for decorative purposes
MATERIAL	Plywood framework Elastic cords (Three colors-70%) under the seat Powder coated metal legs 32 Density Foam Seat High resilient foam core and blown fibre filled back cushions (seperated) (1/3) Hypersoft foam lamination 60gr/m2 fibre lamination
FRAME	All the joints are glued and screwed for added strength. Frames are subjected to tough testing (TSE12520), well in excess of normal domestic use. Fully upholstered with 1 cm foam pad over hand tensioned heavy duty elasticated webbing.
FINISHING OPTIONS	Upholstery: FB1, FB2, EL1, LR1 (Look for the upholstery page for further info) Metal Legs Color: N.0001, N.0020, N.0040, N.7022, N.8019, N.9006, N.9010 Pillows can be filled duck feather (seat or back) upon request and up-charges may apply. Other upholstery and leg options for projects are available upon request.
INSTRUCTIONS	Dry clean only. Unzip cushion covers and dry clean. Remove non-greasy stains by carefully dabbing with a lint-free cloth or sponge wrung out in clean warm water. If necessary, clean by dabbing with soapy water or water with a little dish soap. Finally dab the surface with clean water.
MAINTENANCE	In order to maintain the shape of the pillows, gently beat them with your hands and sculp them back into shape.
GENERAL	In order to maintain the shape of the pillows, gently beat them with your hands and sculp them back into shape.

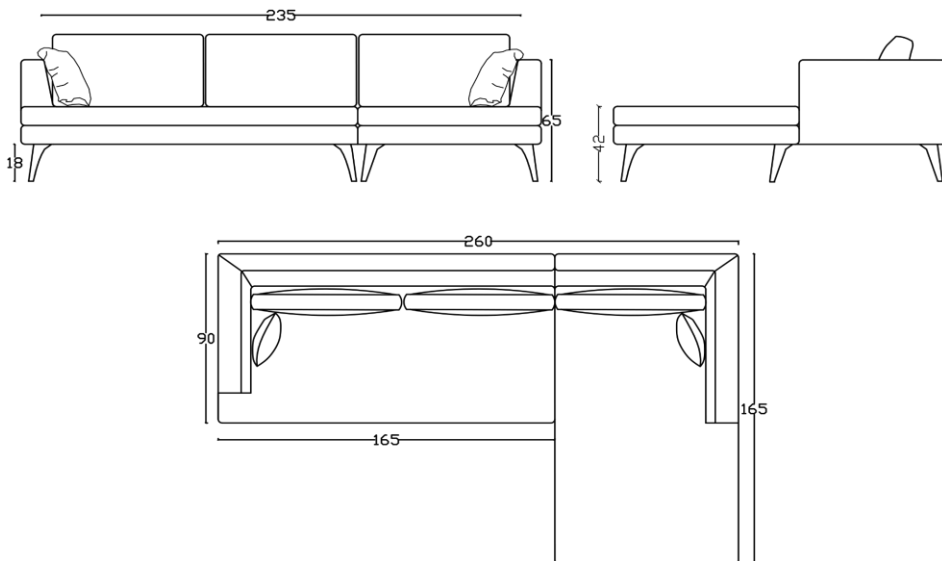

**FONT**  
comfortable sofa